

# PACE

Quality  
Made Affordable...

## 4S Series

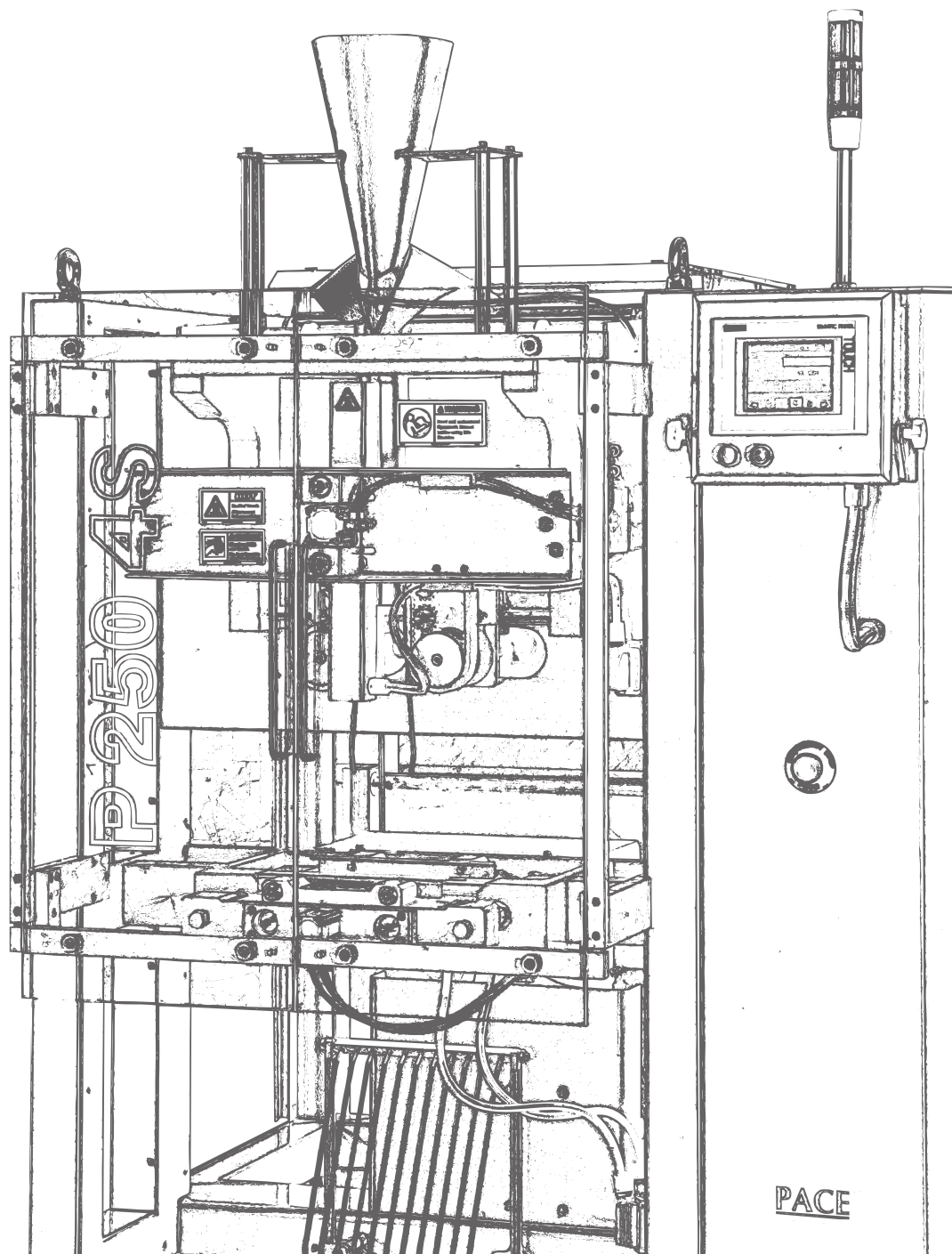

www.pacepackaging.in

PACE

# High Speed Servo Driven

## P250 4S Series

Intermittent Motion Bagging Machine





## Compact & Rugged Structure

The steel frame is designed, fabricated & machined with strong, sturdy & precise components, which ensures long life of the machine with minimum vibrations at optimum machine speed.

## Control System

Each function – sealing, bag pulling, pull roller & unwinding has individual servo motors & drives controlled by high end Motion CPU from SIEMENS – Germany loaded with intelligent software.

All servo motors & key components are networked with PROFIBUS to control & monitor them.

PROFIBUS networking also helps to connect multiple machines for remote monitoring through SCADA.



## Operator Interface

Operator interface is through SIEMENS touch panel and is very user friendly with graphics mounted on the front side of the panel.

## Measure Pull Roll Function

Servo motor controlled measure pull roll which helps to pack unsupported films. It has many advantages over film being directly pulled by coated timing belts from the reel.

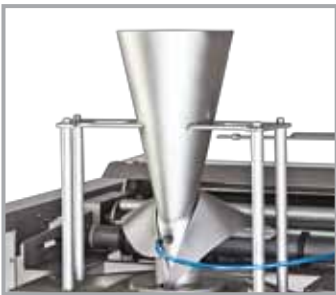

## Forming Parts

One piece forming parts assembly with easy change over. Cross welded hopper with forming tube reduces blockage of the product & also tube length.

## Unwinder

Servo motor driven unwinder unwinds film in synchronization with machine speed & bag length.

Specially designed stainless steel air shaft can easily handle reels with diameter upto 18". This helps to reduce the changeover of reels by 50% with the same output.



## Real Sealing Time

Sealing time remains constant at any given speed. You can increase or decrease the speed of machine without worrying sealing quality.

## Synchronized Filling

Intelligent software decides on its own to drop the product from the filler or weigher, ensuring no product in seal area even while changing speed.

## Integration

PACE Baggers can be integrated with Volumetric Cup Dozers, Auger Fillers, Multihead Combination Weighers, Linear Weighers, etc.

They can be integrated with any type of coders, like hot foil, thermal transfer or inkjet.



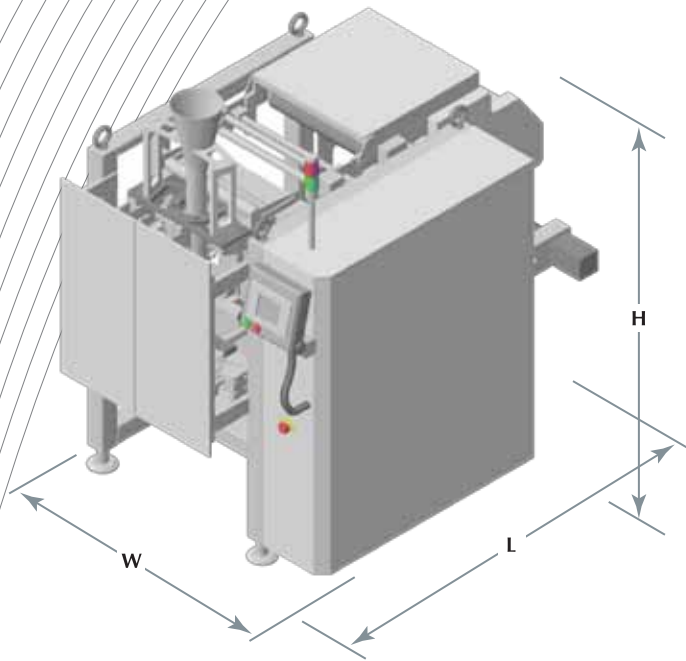

Bag Styles	Max. Speed
Pillow Type Centre Sealed	120 BPM
Gusseted	100 BPM
Block Bottom with Gusseted	90 BPM

## Technical Specification

Machine Specification	P250 4S	P350 4S
Technology	Intermittent Motion	
Bag width	75-250 mm	125-350 mm
Bag Length	375 mm	600 mm
Power Consumption	4 KW/HR	5 KW/HR
Air Requirements	2 CFM @ 6 bar	
Maximum film reel width	530 mm	730 mm
Maximum film reel diameter (D)	450 mm	600 mm
Core diameter	76 mm	
Maximum machine output	120 bags/min.	
Machine weight approximately	950 kg	1075 kg
Dimensions L x W x H (mm)	1840x1360x1920	2050x1550x2150

All specification on this leaflet can be subject to change without prior notification from PACE.



# PACE

## PACE PACKAGING MACHINES PVT. LTD.

Plot No. 377A, Road No. 9, G.I.D.C., Kathwada, Ahmedabad - 382 430, Gujarat, INDIA.

Tel.: +91-79-2290 1980 / 81

E mail : info@pacepackaging.in

www.pacepackaging.in